

Modulift®

working between the hook and the load



**Modular Spreader Beams • Lifting Beams
Spreader Frames • Custom Design and Manufacture**

Modulift: Working Between the Hook and the Load

Our Vision

To be renowned globally as specialist engineers operating in a niche market, concentrating on the provision of custom and complex lifting solutions and exceeding our customers expectations by providing an all round service on the delivery of value for money and quality products.

Our Mission

To globally deliver our expertise through innovative designs of quality products and customer satisfaction whilst ensuring a safe lifting environment.

Our Values

- Leadership: Driving the standard of lifting products higher
- Passion: Committed to delivering high quality products and ensuring safety comes first
- Innovation: Inspiring engineering genius
- Quality: We do what we do well

At Modulift, we pride ourselves on being able to offer you a complete lifting engineering service from start to finish. We are here to help you solve your lifting problems, advise on rig planning, design custom lifting equipment, or manufacture quality assured products to the highest specifications.



Standard Off-the-Shelf Range

*MOD and CMOD are trademarks of Modulift UK Ltd

Standard Made-to-Order Range

QJ2 Up to 2t at 1.2m/4ft	MOD 24 Up to 24t at 5m/17ftUp to 8m/26ft at a lower capacity	MOD 70 Up to 70t at 10.5m/34ftUp to 14m/45ft at a lower capacity	MOD 110H Up to 170t at 11.5m/37ftUp to 18m/59ft at a lower capacity	MOD 250/300 Up to 300t at 13m/40ftUp to 21m/68ft at a lower capacity	MOD 400/500 Up to 500t at 15m/50ftUp to 24m/78ft at a lower capacity	MOD 600/800 Up to 800t at 18m/60ftUp to 26m/85ft at a lower capacity
MOD 6 Up to 6t at 3.6m/148"Up to 4.5m/176" at a lower capacity	MOD 34 Up to 34t at 6m/19ftUp to 10m/32ft at a lower capacity	MOD 70H Up to 100t at 8.5m/28ftUp to 14m/45ft at a lower capacity	MOD 110SH Up to 240t at 10.5m/34ftUp to 17m/55ft at a lower capacity	MOD 250/400 Up to 400t at 11m/36ftUp to 21m/68ft at a lower capacity	MOD 400/600 Up to 600t at 14m/46ftUp to 24m/78ft at a lower capacity	MOD 600/1000 Up to 1000t at 15m/50ft and up to 26m/85ft at a lower capacity
MOD 12 Up to 12t at 4.75m/15ftUp to 6.5m/21ft at a lower capacity	MOD 50 Up to 50t at 8m/26ftUp to 13m/42ft at a lower capacity	MOD 110 Up to 110 t at 14m/46ftUp to 18m/59ft at a lower capacity	MOD 250/250 Up to 250t at 14m/46ftUp to 21m/68ft at a lower capacity	MOD 400/400 Up to 400t at 17m/58ftUp to 24m/78ft at a lower capacity	MOD 600/600 Up to 600t at 21m/70ftUp to 26m/85ft at a lower capacity	MOD 1100/2000 Up to 2000t at 26m/85ft and up to 36m/118ft at a lower capacity

Modular Spreader Beams

Modular Spreader Beams provide the ideal solution for most lifting requirements – versatile and cost-effective, the Modulift range has capacity from 2t to 5000t with spans up to 330ft/100m. The modular configuration and interchangeable components enable Modulift Spreaders to be reused over many lifts. Designed by our engineering experts and manufactured in our own specialist facilities; the Modulift range are the leading Modular Spreader Beams on the market.

Spreader Beams up to 600t are in stock and available worldwide for distribution – please contact Modulift for an immediate quote or further details.

Every Modulift Modular Spreader Beam consists of a pair of End Units and a pair of Drop Links, with interchangeable struts that can be bolted into the assembly between the End Units to either lengthen or shorten the beam to suit the requirements of the lift, making them reusable at different spans.

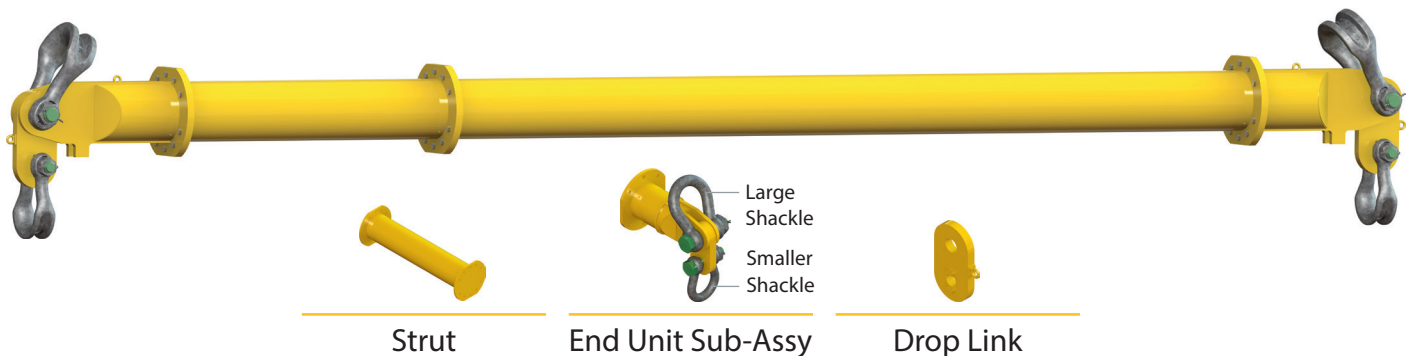

Flexibility beyond the Spreader Beam

Using our range of interchangeable corner units and T-pieces, Modulift struts can be used throughout the product portfolio to achieve a variety of configurations including 3-point, 4-point, 6-point and 8-point frames. End units also offer maximum flexibility with trunnion and Clevis drop link options enabling the user to have two slings hung from each end of the beam for a variety of benefits. Call or email us for more information.

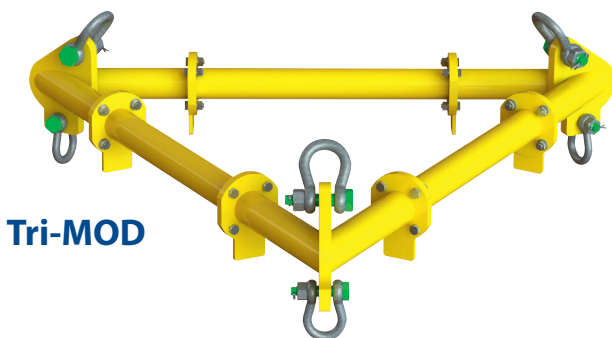

CMOD

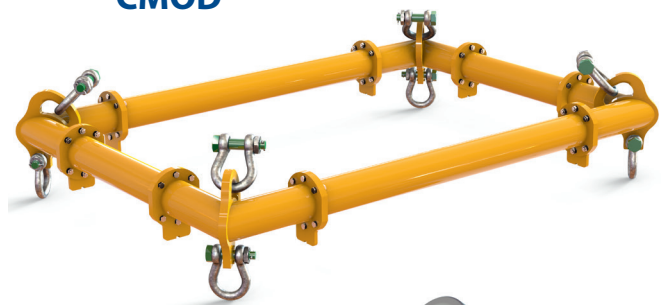

Trunnion End Units



The Standard Range

Load v Span Chart - Modulift Spreader Beam MOD 6 to MOD 70H

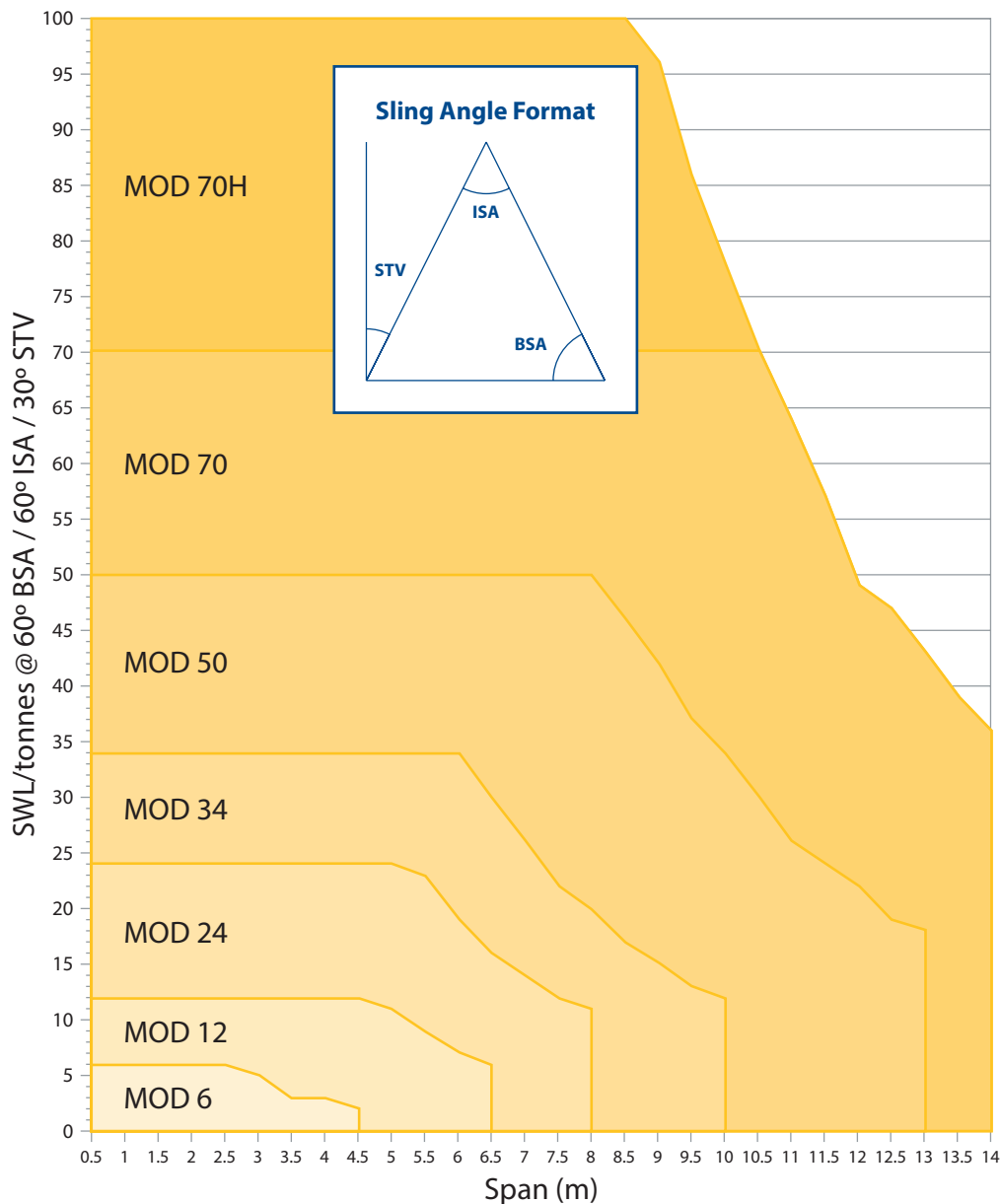

What size shackle do I need?

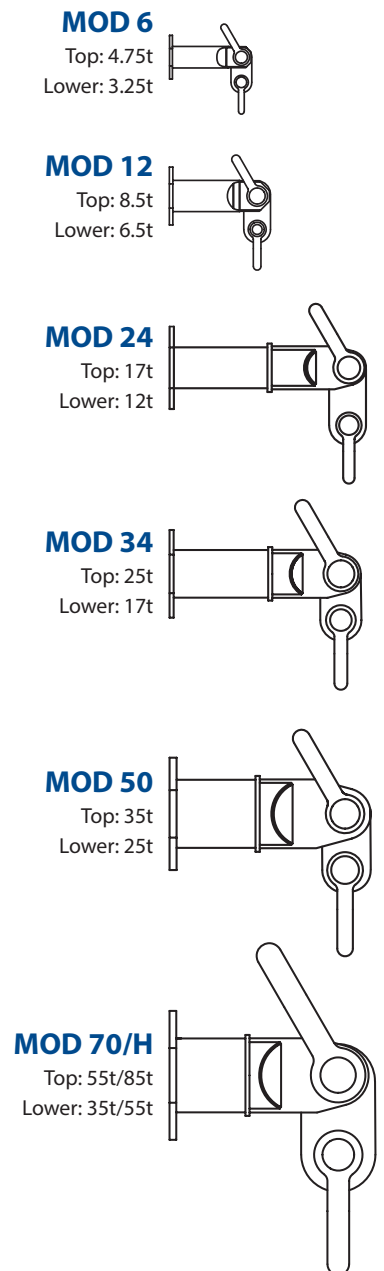

Components per Set

* Please note: Custom length Struts are available on request

Spreader System	Strut													End unit	Drop link
	0.1m	0.2m	0.25m	0.3m	0.5m	0.6m	0.75m	1.0m	1.5m	2.0m	3.0m	4.0m	6.0m		
MOD 6	1	1		1		1		4						2	2
MOD 12			1		1		1	1	3					2	2
MOD 24					1			1		3				2	2
MOD 34					1			1		4				2	2
MOD 50					1			2		1		2		2	2
MOD 70/70H					1			1		2		2		2	2
MOD 110/110H					1			1		2		3		2	2
MOD 110SH					1			1		1		3		2	2
MOD 250-250 / 250-300 / 250-400					1			1		2	1		2	2	2
MOD 400-400 / 400-500 / 400-600					1			1		1	1		3	2	2
MOD 600-600 / 600-800 / 600-1000					1			1		1	1		3	2	2

Load v Span Chart - Modulift Spreader Beam MOD 110 to MOD 600/1000*

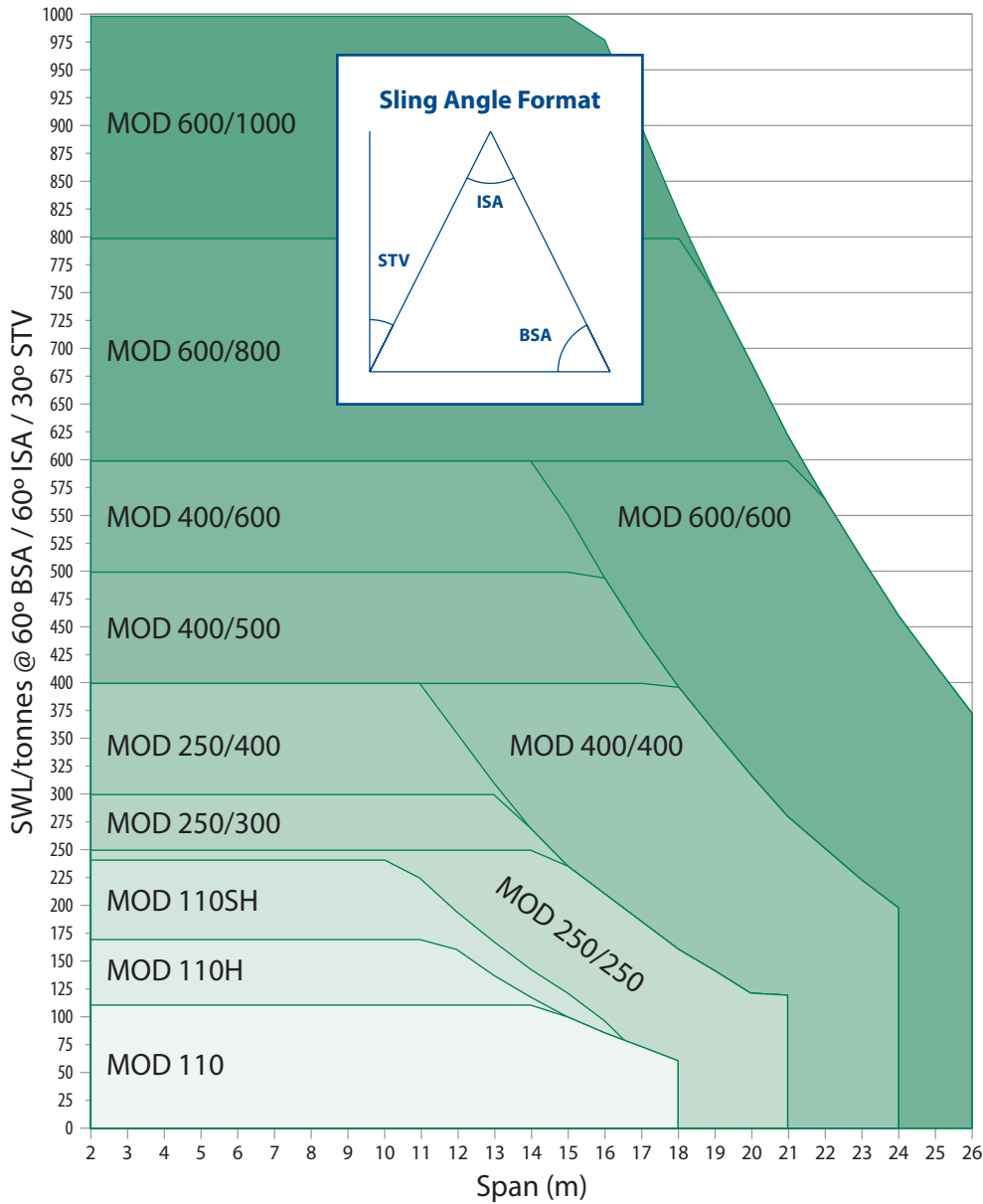

What size shackle do I need?

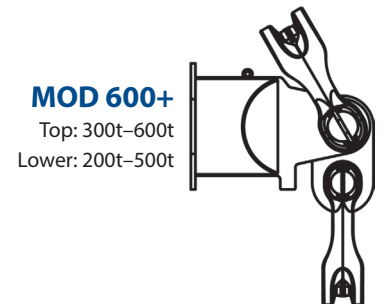
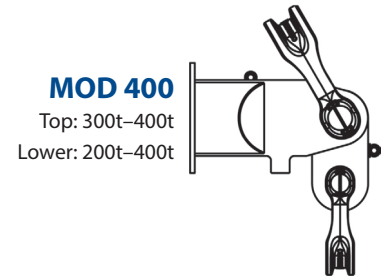
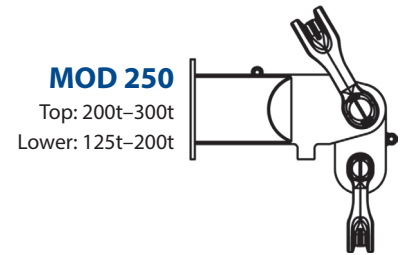
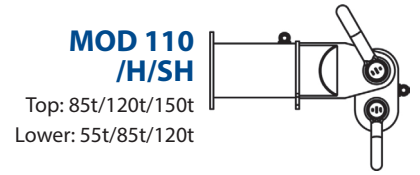

*Load v Span Charts exceeding 1000t are available on request

Weight per Set (kgs)

* Weight based on heaviest spreader in series using configuration recommended in user instructions

Weight	MOD 6	MOD 12	MOD 24	MOD 34	MOD 50	MOD 70, 70H	MOD 110, 110H	MOD 110SH	MOD 250	MOD 400	MOD 600
Max. Component Weight	8.1	19	41	51	140	240	367	444	860	1365	2665
Min. Component Weight	0.6	1.3	5	7	11	17 / 32	44 / 55	63	90	135	135
Weight at Max. Span	32	75	178	290	532	972/1090	1970/2130	2628	4895	8260	17260

Born in the UK, raised around the world

Why are Modulift the leading global spreader beam designer and manufacturer in the market?

Quality Engineering	Modulift are a team of specialist engineers designing innovative products to optimum specification to ensure a safe lifting environment around the world.
Stock Holding Distributors	Modulift has over 30 stock holding distributors strategically located worldwide allowing you to purchase certified Spreader Beams or components wherever your project is.
Standards and Regulations	Conforming with all international standards, Modulift Spreader Beams are certified wherever you are working.
DNV Type Approval	Modulift Spreader Beams have DNV Type Approval up to 2000t eliminating the need for additional proof load testing.
Interchangeable	The modular design allows for multiple lengths to be configured for a variety of lifts. Mix and match end units with struts when long spans and lightweight lifts are required.
Economical	The modularity of Modulift's Spreader Beam systems enables one beam to perform a variety of lifts by utilizing the different strut configurations and end units.
Portable	Our longest strut is only 6m/20' – short enough for the back of a truck! Many of our Spreader Beam components can be handled by one person. Our QJ2 even comes in a handy carrying case complete with Shackles!
Lightweight	Our Spreader Beams are specially designed to provide you with a lightweight solution so your cranes can work at maximum capacity without the weight of heavy lifting gear.
Custom Applications	While the Modulift Spreader Beam systems aim to provide a solution for almost any lift we understand that not all lifts are equal. We can design and build a custom solution whatever your needs. Contact us today!

Multi-point lifting frames

Spreader Frames and Lifting Frames are recommended for loads that have more than two lifting points; they can also be the ideal lifting equipment for when headroom is limited. Modulift offer several types of Spreader Frames and Lifting Frames for Multi-Point Lifts

CMOD Spreader Frames

Our most economical option is the newly designed CMOD Modular Spreader Frame. Lighter and stronger with newly designed corner units giving a 40% weight saving, the CMOD is designed to expand the capabilities of our Modular Spreader Beam System. The struts from the Spreader Beam are combined with 4 Corner Units to complete the Frame. Customers that already have Modulift struts can re-use these with the Corner Units to achieve 4-Point lifts, making this a versatile solution. The CMOD Spreader Frame is currently available from the CMOD 6 up to the CMOD 250. The systems will lift up to 300t.

CMOD T-Pieces

Expanding on a very popular CMOD Spreader Frame, Modulift have designed and manufactured a T Piece to further develop the capabilities of the CMOD Spreader Frame. This additional connection allows the frame to become a 6 point or 8 point frame.

Benefits:

- With more lifting points, there is more support for multi-point lifts
- Reduces the rigging compared to a cascading spreader beam arrangement
- Lower head room compared to a cascading spreader beam arrangement

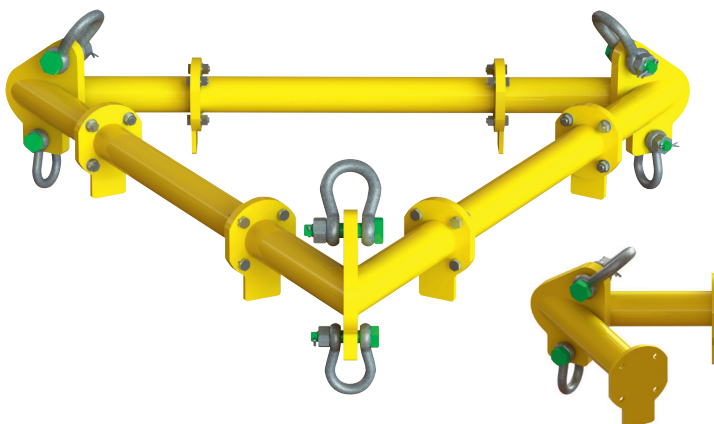
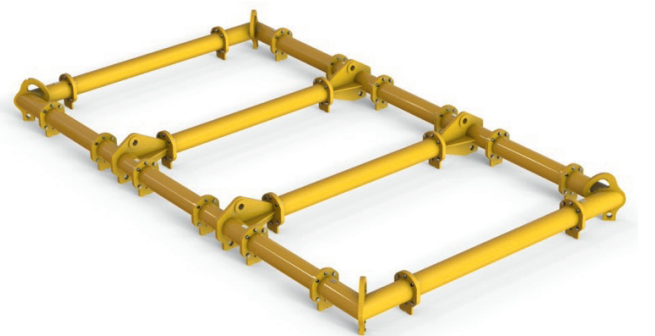
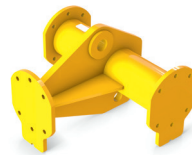
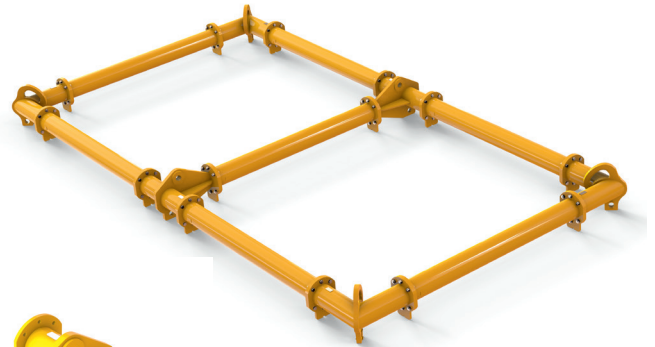

Tri-MOD

The Tri-MOD is a triangular frame once again utilizing the struts from the Modular Spreader Beam range. The Tri-MOD is popular for many 3-point lift requirements including circular lifts.

CMOD Load Charts

Load vs Span Charts – CMOD 6 to CMOD 24

CMOD 6: SWL / tonnes @ 60° ISA / 30° STV / 60° BSA

2.5					8
2				8	8
1.5			8	8	8
1		8	8	8	6
0.5	8	8	8	6	6
Span (m)	0.5	1	1.5	2	2.5

CMOD 6: SWL / tonnes @ 90° ISA / 45° STV / 45° BSA

2.5					6
2				6	6
1.5			6	6	6
1		6	6	6	4
0.5	6	6	6	4	4
Span (m)	0.5	1	1.5	2	2.5

CMOD 12: SWL / tonnes @ 60° ISA / 30° STV / 60° BSA

4								16
3.5							16	16
3						16	16	15
2.5					16	16	15	14
2				16	16	16	14	13
1.5			16	16	16	16	14	12
1		16	16	16	16	16	14	12
0.5	16	16	16	16	16	16	14	12
Span (m)	0.5	1	1.5	2	2.5	3	3.5	4

CMOD 12: SWL / tonnes @ 90° ISA / 45° STV / 45° BSA

4								9
3.5							9	9
3						9	9	8
2.5					9	9	8	8
2				9	9	9	8	7
1.5			9	9	9	9	8	6
1		9	9	9	9	9	8	6
0.5	9	9	9	9	9	9	8	6
Span (m)	0.5	1	1.5	2	2.5	3	3.5	4

CMOD 24: SWL / tonnes @ 60° ISA / 30° STV / 60° BSA

6						23
5					30	21
4				30	24	19
3			30	30	24	18
2		30	30	30	24	17
1	30	30	30	24	22	16
Span (m)	1	2	3	4	5	6

CMOD 24: SWL / tonnes @ 90° ISA / 45° STV / 45° BSA

6						13
5					17	12
4				19	13	10
3			19	19	13	10
2		19	19	17	13	9
1	19	19	19	13	12	9
Span (m)	1	2	3	4	5	6

Load vs Span Charts – CMOD 34 to CMOD 70*

*CMOD 110 and CMOD 250 graphs available on request

CMOD 34: SWL / tonnes @ 60° ISA / 30° STV / 60° BSA

8								24
7							32	23
6						40	31	22
5					40	40	28	20
4				40	40	34	26	19
3			40	40	40	34	24	18
2		40	40	40	40	32	23	17
1	40	40	40	40	34	30	22	16
Span (m)	1	2	3	4	5	6	7	8

CMOD 34: SWL / tonnes @ 90° ISA / 45° STV / 45° BSA

8								13
7							18	13
6						22	17	12
5					27	22	16	11
4				27	27	19	15	10
3			27	27	25	19	13	10
2		27	27	27	22	18	13	9
1	27	27	27	27	19	17	12	9
Span (m)	1	2	3	4	5	6	7	8

CMOD 50: SWL / tonnes @ 60° ISA / 30° STV / 60° BSA

11											32
10										41	31
9									50	39	29
8								50	48	37	28
7							60	50	45	35	27
6						60	60	50	43	33	26
5					60	60	60	50	40	32	25
4				60	60	60	50	49	38	31	24
3			60	60	60	60	50	47	37	30	23
2		60	60	60	60	60	50	45	36	29	23
1	60	60	60	60	60	60	50	44	35	28	22
Span (m)	1	2	3	4	5	6	7	8	9	10	11

CMOD 50: SWL / tonnes @ 90° ISA / 45° STV / 45° BSA

11											18
10										23	17
9									28	21	16
8								28	27	20	15
7							34	28	25	19	14
6						40	34	28	24	18	14
5					40	40	34	28	23	17	13
4				50	40	40	28	28	21	17	13
3			50	50	40	40	28	26	21	16	12
2		50	50	50	40	34	28	25	20	16	12
1	50	50	50	50	40	34	28	25	20	15	12
Span (m)	1	2	3	4	5	6	7	8	9	10	11

CMOD 70: SWL / tonnes @ 60° ISA / 30° STV / 60° BSA

12												63
11											70	60
10										80	70	58
9									80	80	70	55
8								80	80	80	67	53
7							80	80	80	70	65	51
6						80	80	80	70	60	62	49
5					80	80	80	80	70	60	60	47
4				80	80	80	80	80	70	60	58	46
3			80	80	80	80	80	80	70	60	56	45
2		80	80	80	80	80	80	70	70	60	55	44
1	80	80	80	80	80	80	80	70	70	60	54	44
Span (m)	1	2	3	4	5	6	7	8	9	10	11	12

CMOD 70: SWL / tonnes @ 90° ISA / 45° STV / 45° BSA

12												36
11											40	34
10										40	40	33
9									46	40	40	31
8								57	46	40	38	30
7							60	57	46	40	37	29
6						60	60	57	40	34	35	28
5					60	60	60	50	40	34	34	27
4				60	60	60	60	50	40	34	33	26
3			60	60	60	60	60	50	40	34	32	26
2		60	60	60	60	60	60	50	40	34	31	25
1	60	60	60	60	60	60	60	50	40	34	31	24
Span (m)	1	2	3	4	5	6	7	8	9	10	11	12

TriMOD Load Charts

Load v Span Chart - Modulift Tri-MOD 45° STV

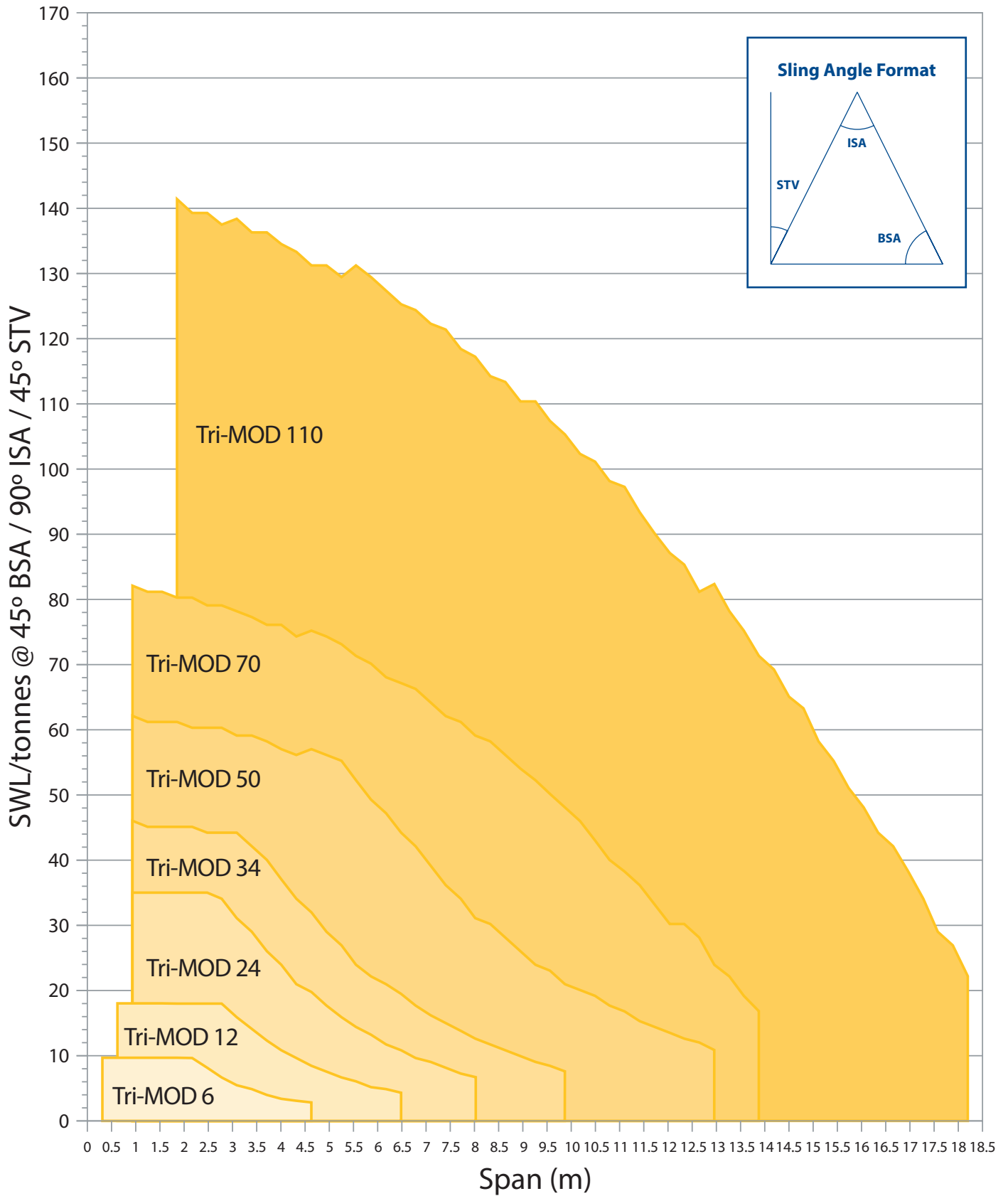

Load v Span Chart - Modulift Tri-MOD 30° STV

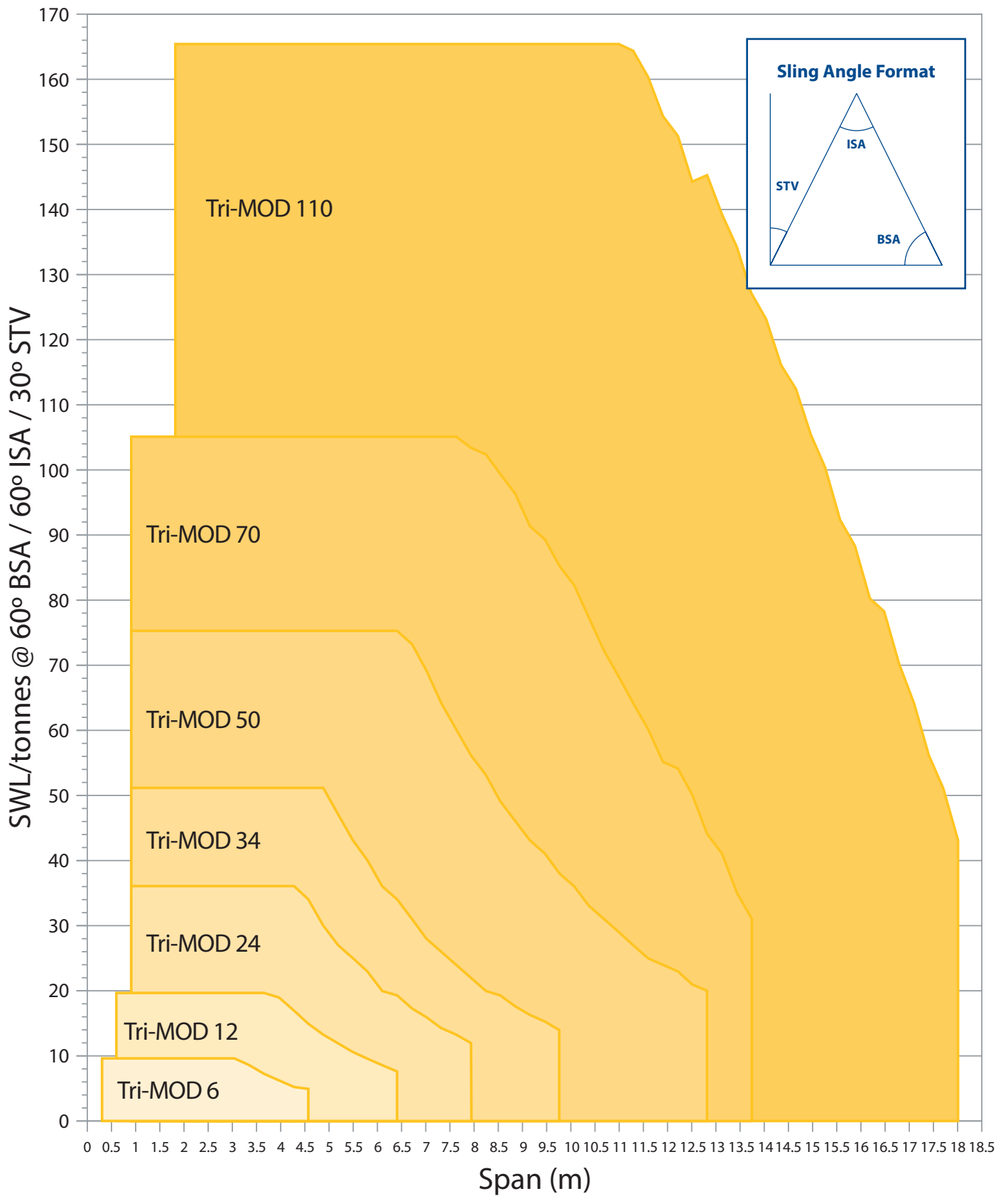

The Multi-Point Beam

The Multi-Point Beam is the most adaptable in the Modulift range

The Multi-Point gives unrivalled Modulift strength and reliability with additional features to suit different lifting scenarios.

With lifting points on the top and bottom, the Multi-Point Beam is an innovative piece of kit that can be reused for multiple lifts.

The Multi-Point can be supplied with or without swivel hook, allowing for tandem lifts where there is only one lower lifting point required. It can be used as a semi-spreader to give a steadier lift, and as a Lifting Beam where headroom is limited.



The Standard Multi-Point Beam



The Multi-Point Beam with Optional Swivel Hook



One Beam, Many Uses

The Multi-Point Beam is an essential piece of equipment for use across a whole host of lifting applications. Helping you lift even the most heavy, long or awkward item, and saving rigging time in the process. The Multi-Point is engineered for multiple use giving greater flexibility than a standard beam. A fully adjustable and modular lifting solution.

Semi-Spreader Beam

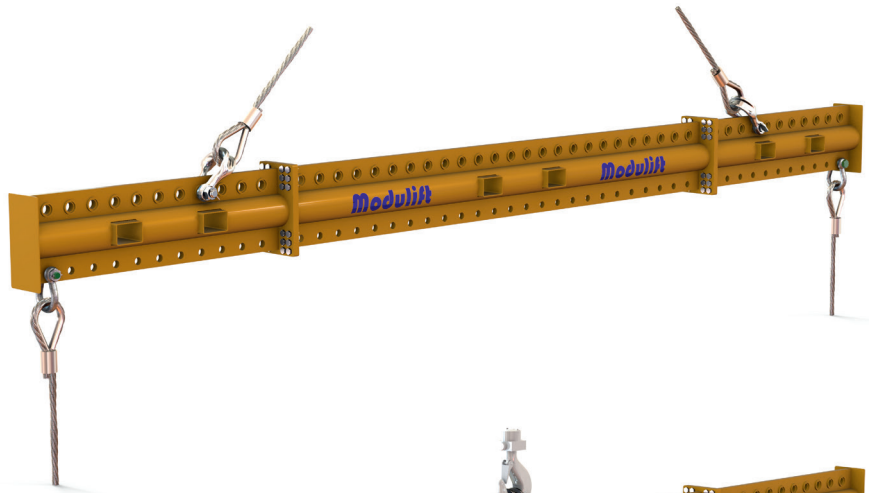

Lifting Beam for Low Headroom Applications

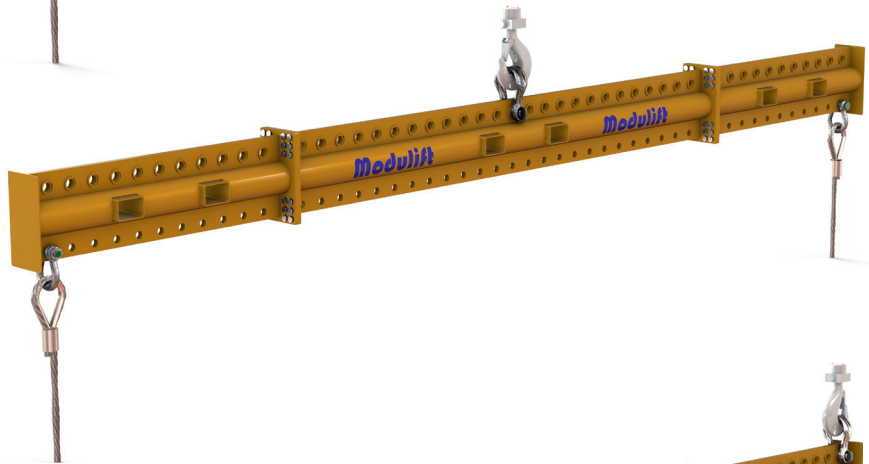

Tandem Lift

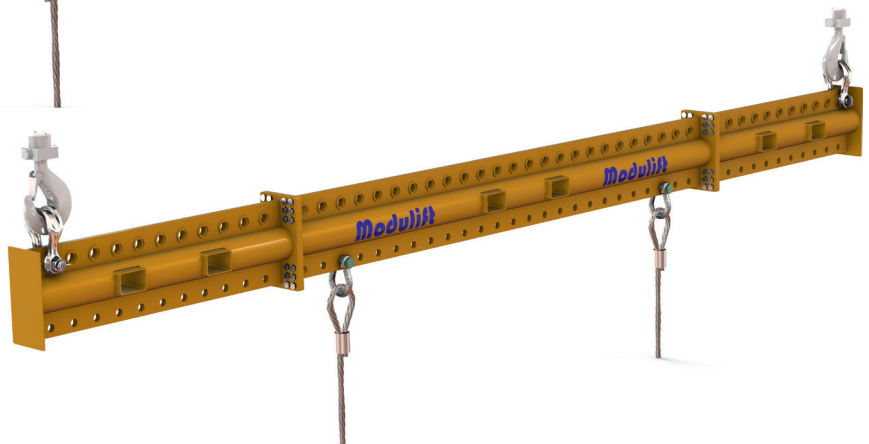

Why choose the Multi-Point Beam?

- Versatile - can be used as a lifting beam, semi-spreader or for tandem lifts
- Fully adjustable – beam can be reused over many lifts in different set-ups
- Modular design – different length struts are available
- Optional hook – available with or without swivel hook

CLS - Clamp Lifting System

The Modulift CLS clamp lifting system provides a safe, fast, and adjustable beam, enabling users to lift from multiple points!

The MOD CLS clamps are stocked as a boxed product for immediate shipping that eliminates delays incurred waiting for alternative solutions, which often have to be manufactured to order.

The MOD CLS is currently available in several sizes from 8.5t to 27t capacity, depending on configuration, and offered with four clamps as standard to adjust the lifting points to enable flexibility between a single top lifting point (lifting beam) or two top lifting points (semi spreader beam).

The pre-assembled clamps are supplied ready to fit on the beam. The beam is able to be pre-marked to assist with clamp placement for all configurations shown on our User Instructions.

Additional clamps can be purchased to enable multiple lower lifting points to be utilized.

Now
available
with a WLL
of 27t

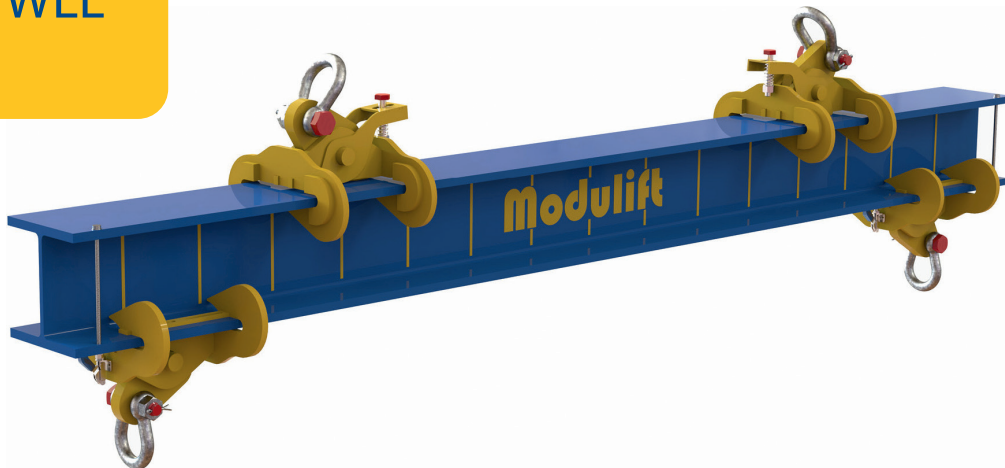
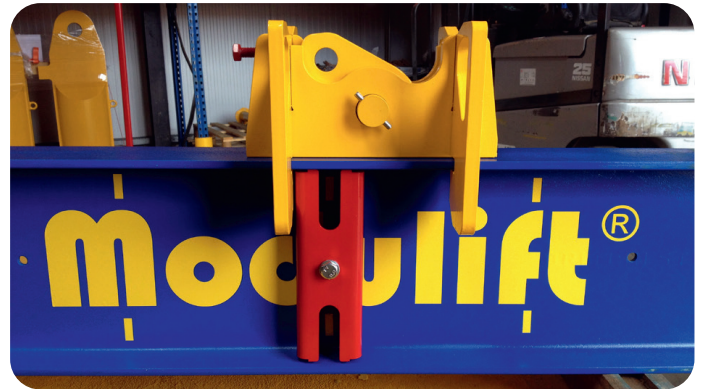

System Benefits

- Available next day as a boxed off-the-shelf product
- Adjustable lifting points and low headroom capability
- Easy to convert between a Lifting Beam and Spreader Beam
- Spans of up to 6m and capacities of up to 8.5t depending on configuration

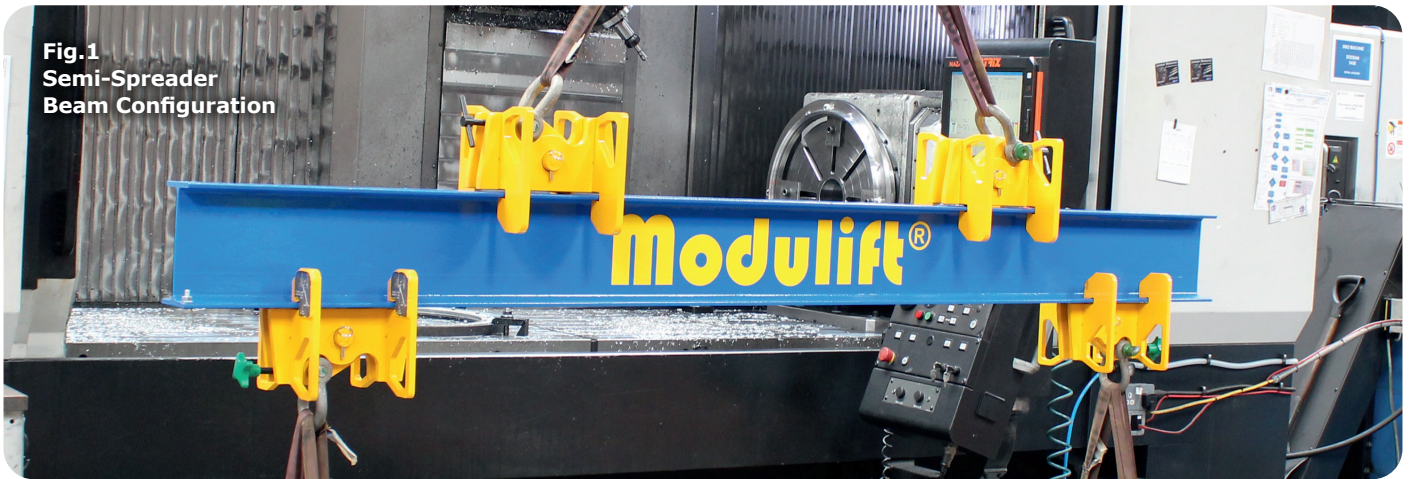

Fig. 1
Semi-Spreader
Beam Configuration



Fig. 2
Lifting Beam
Configuration

MOD CLS Specification

- The MOD CLS is rated at 8.5t WLL at 3m span (spreader arrangement). See Load Tables for WLL at other configurations.
- 'Sling to Vertical', β , up to 30 degrees maximum.
- The top Lifting Beam Clamp is rated at 6.5t WLL (vertical) and 4.4t WLL (0–30° STV).
- The bottom Lifting Beam Clamp is rated at 4.75t WLL (vertical).

WLL v Span Semi-Spreader configuration (2 top lugs, Fig. 1)

If your exact spans are not noted in the table, then please round the spans up or down to the values that will give you the lowest SWL.

WLL (t)		A – Top Clamp Span (m)						
		<0.5	1	2	3	4	5	6
B – Bottom Span (m)	<0.5	8.5	8	7	3.75	2.25	1.25	0.8
	1	8	8.5	8	5.25	2.75	1.5	1
	2	7.5	8	8.5	7.75	4	2.25	1.25
	3	4.25	6.25	8	8.5	6	3	2
	4	2.25	3	4.75	8	8	4.5	2.25
	5	1.25	1.75	2.25	3.75	7	7.5	3.5
	6	0.8	1	1.25	2	3	5.25	6.25

Lifting Beam configuration (1 top lug, Fig. 2)

B – Bottom Span (m)	≤ 2	≤ 3	≤ 4	≤ 5	≤ 6
WLL (t)	6.2	4.25	2.25	1.25	1

Contact Modulift if you need a specific WLL value for a specific span or arrangement not covered on the tables above.

Subsea Spreader Beams

The Modulift Subsea Spreader Beam has an open section design, therefore being suitable for water submersion by eliminating the risks of any cavity or pressure issues.



The Subsea Spreader Beam series is available for order while for more job specific requirements or high QA lifts, the Modulift engineering team can design custom made lifting alternatives.

Complying with 'DNV-OS-H206 – Loadout, Transport and Installation of Subsea Objects', the Modulift Subsea range is designed to safely lift loads up to up 570t.

As with regular Spreader Beams they are fully and correctly assembled when combined with the recommended end units, drop links and shackles top and bottom, which also allows for the options to use ROV shackles where necessary too. Their unique modular elements will as with all Modulift products, provide a versatile and efficient option for deep water lifting and offshore lifting.



System Benefits

- DNV compliant
- Deep water lifting system
- Lightweight design
- Modular

Load v Span Charts - Modulift Subsea Spreader Beam Range

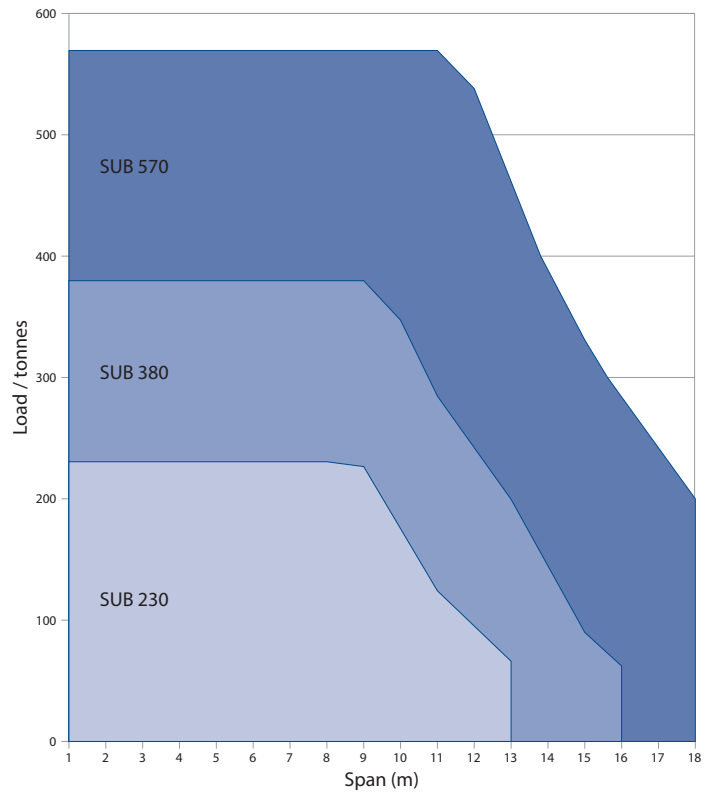
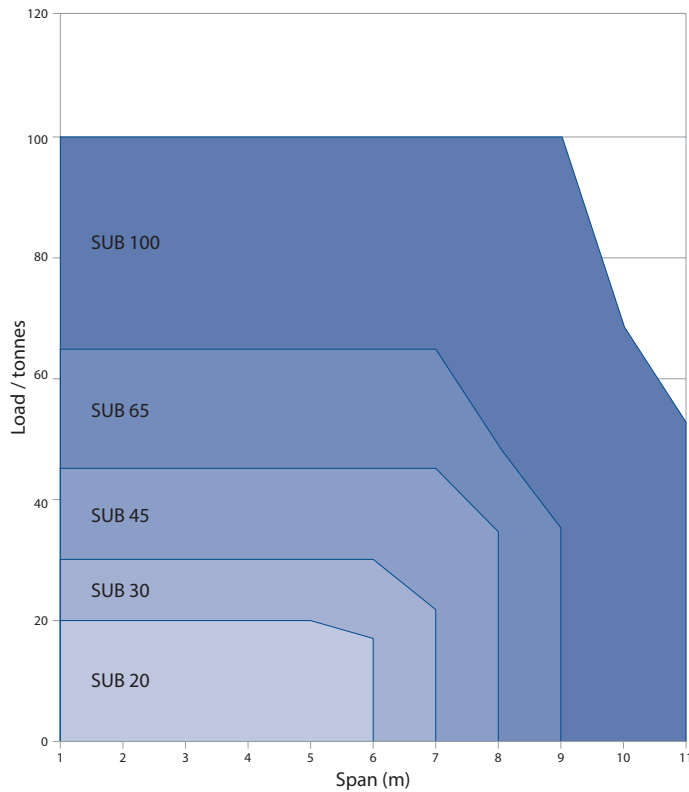

Subsea Spreader Range Load vs Span Chart 30° STV

Span / m	SUB 20	SUB 30	SUB 45	SUB 65	SUB 100	SUB 230	SUB 380	SUB 570	Min. sling length / m
	SWL / tonnes								
1	20	30	45	65	100	230	380	570	1
2	20	30	45	65	100	230	380	570	2
3	20	30	45	65	100	230	380	570	3
4	20	30	45	65	100	230	380	570	4
5	20	30	45	65	100	230	380	570	5
6	17	30	45	65	100	230	380	570	6
7		22	45	65	100	230	380	570	7
8			35	49	100	230	380	570	8
9				36	100	228	380	570	9
10					69	183	345	570	10
11					53	128	285	570	11
12						100	239	535	12
13						66	198	455	13
14							140	388	14
15							90	327	15
16							63	282	16
17								238	17
18								201	18

Lattice Spreader Beams



Modulift's standard modular Lattice Beams are ideal for lifting longer, lighter loads. For example, long, flexible pipe sections or roof sheet packs that require multiple supports along the span.

Modulift offer 3t and 5t capacities as standard, with spans up to 30m unsupported centrally, and up to 42m utilising a simple central support sling system. Please contact Modulift for more detail on this if unsure. For heavier more complex lifts, Modulift can also offer a custom solution lattice with capacities 5t–150t.

Lifting Points/Load Connection Points 6–15m Span

● = connection point for cross bar, and/or connection point for sling to weld eye.
 LC = Lattice Connections
 CB = Cross Beams

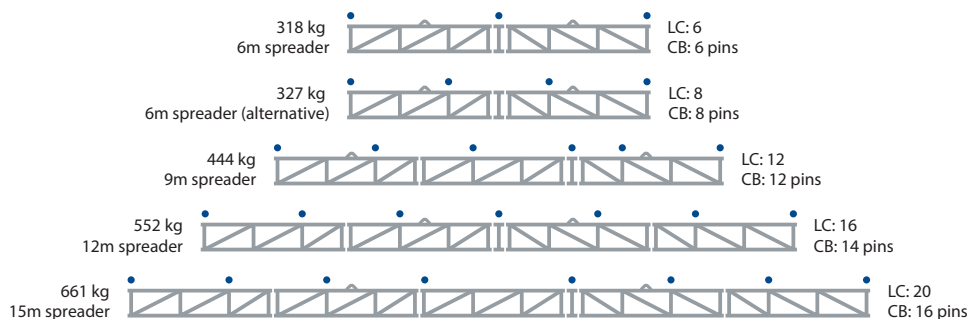

Spreader	Configuration (frame types)							No. of Crossbeams
6m	2	3	2					3 or 4
9m	2	1	3	2				6
12m	1	2	3	2	1			7
15m	1	2	1	3	2	1		8
1=Type 1 Frame 2=Type 2 Frame 3=Type 3 Frame		Maximum 1.5m overhang of roofing sheet per end						

Assembled 18m Lattice Spreader Beam

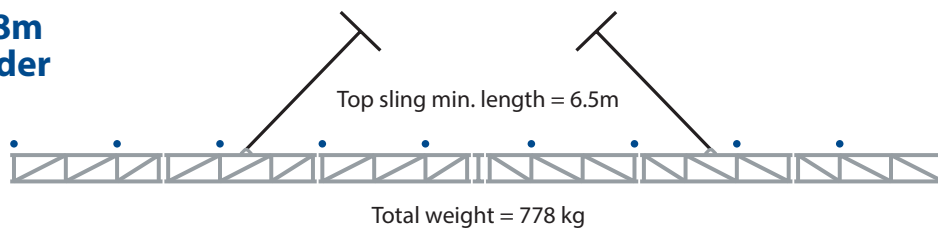

Spreader	Configuration (frame types)								No. of Crossbeams
18m	1	2	1	3	1	2	1	10	
Type 1 Frame x4 Type 2 Frame x2 Type 3 Frame x1	Maximum 1.5m overhang of roofing sheet per end								

Assembled 21m Lattice Spreader Beam

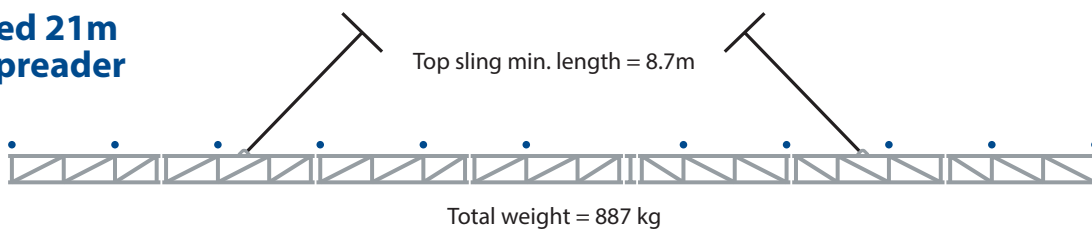

Spreader	Configuration (frame types)								No. of Crossbeams
21m	1	2	1	1	3	1	2	1	11
Type 1 Frame x5 Type 2 Frame x2 Type 3 Frame x1	Maximum 1.5m overhang of roofing sheet per end								

Assembled 24m Lattice Spreader Beam

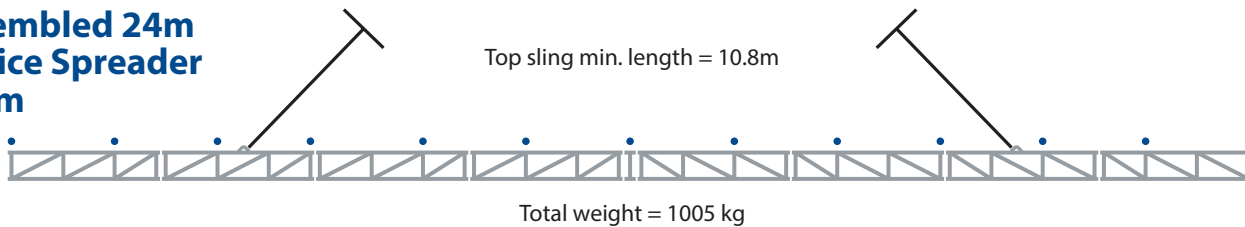

Spreader	Configuration (frame types)								No. of Crossbeams	
24m	1	2	1	1	3	1	1	2	1	13
Type 1 Frame x6 Type 2 Frame x2 Type 3 Frame x1	Maximum 1.5m overhang of roofing sheet per end									

Assembled 27m Lattice Spreader Beam

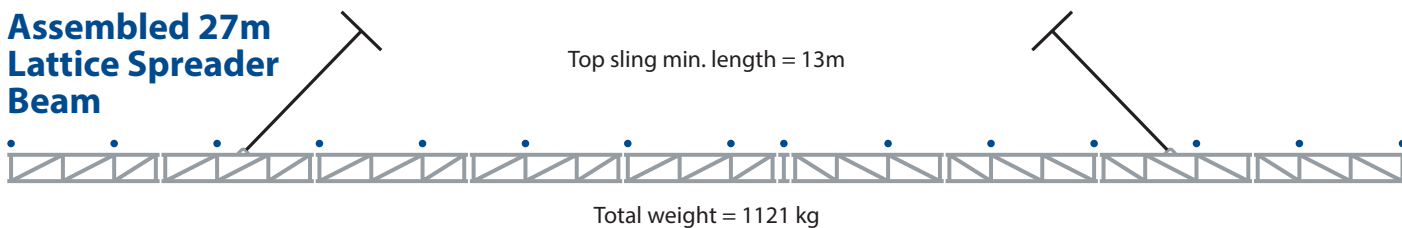

Spreader	Configuration (frame types)								No. of Crossbeams		
27m	1	2	1	1	1	3	1	1	2	1	15
Type 1 Frame x7 Type 2 Frame x2 Type 3 Frame x1	Maximum 1.5m overhang of roofing sheet per end										

Lattice Spreader Beams (continued)

Assembled 30m Lattice Spreader Beam

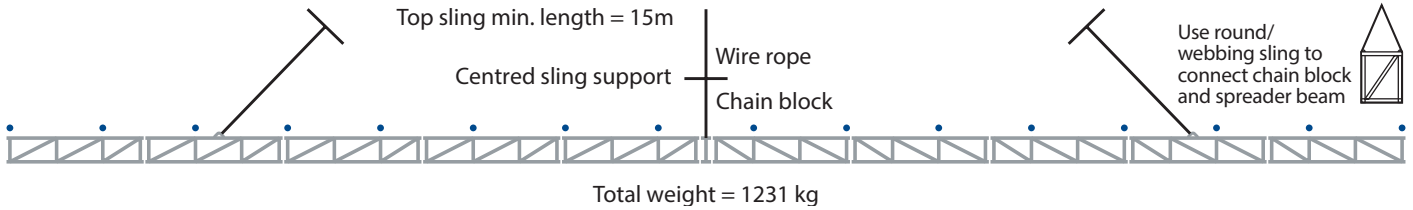

Spreader	Configuration (frame types)											No. of Crossbeams
30m	1	2	1	1	1	3	1	1	1	2	1	16
Type 1 Frame x8 Type 2 Frame x2 Type 3 Frame x1	Maximum 1.5m overhang of roofing sheet per end											

Assembled 33m Lattice Spreader Beam

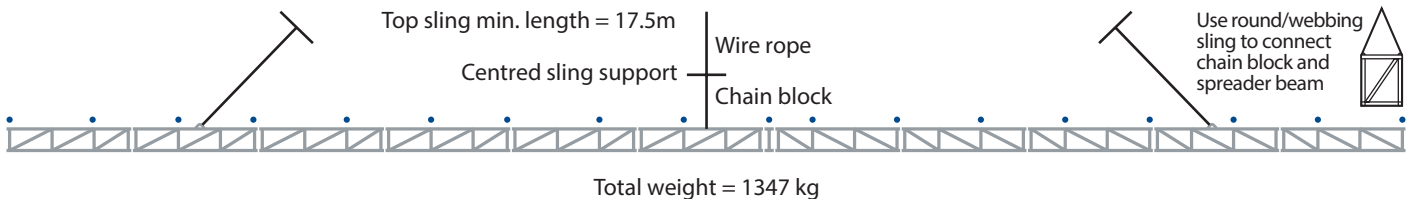

Spreader	Configuration (frame types)											No. of Crossbeams	
33m	1	2	1	1	1	1	3	1	1	1	2	1	18
Type 1 Frame x9 Type 2 Frame x2 Type 3 Frame x1	Maximum 1.5m overhang of roofing sheet per end												

Assembled 36m Lattice Spreader Beam

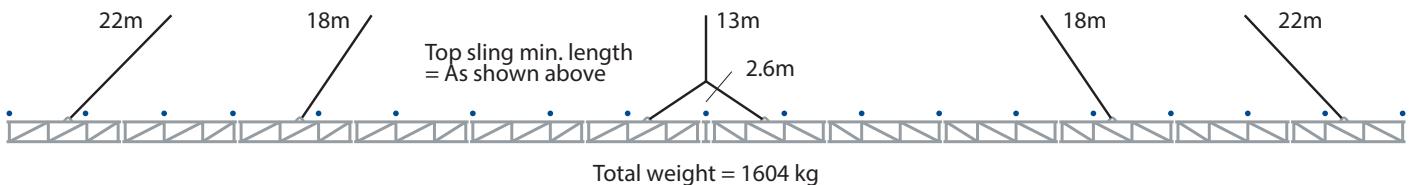

Spreader	Configuration (frame types)												No. of Crossbeams	
36m	2	1	2	1	1	2	3	2	1	1	2	1	2	19
Type 1 Frame x6 Type 2 Frame x6 Type 3 Frame x1	Maximum 1.5m overhang of roofing sheet per end													

Assembled 42m Lattice Spreader Beam

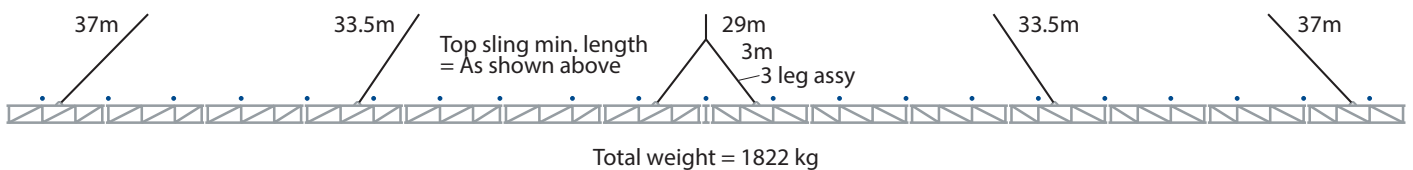

Spreader	Configuration (frame types)													No. of Crossbeams	
42m	2	1	1	2	1	1	2	3	2	1	1	2	1	2	21
Type 1 Frame x8 Type 2 Frame x6 Type 3 Frame x1	Maximum 1.5m overhang of roofing sheet per end														

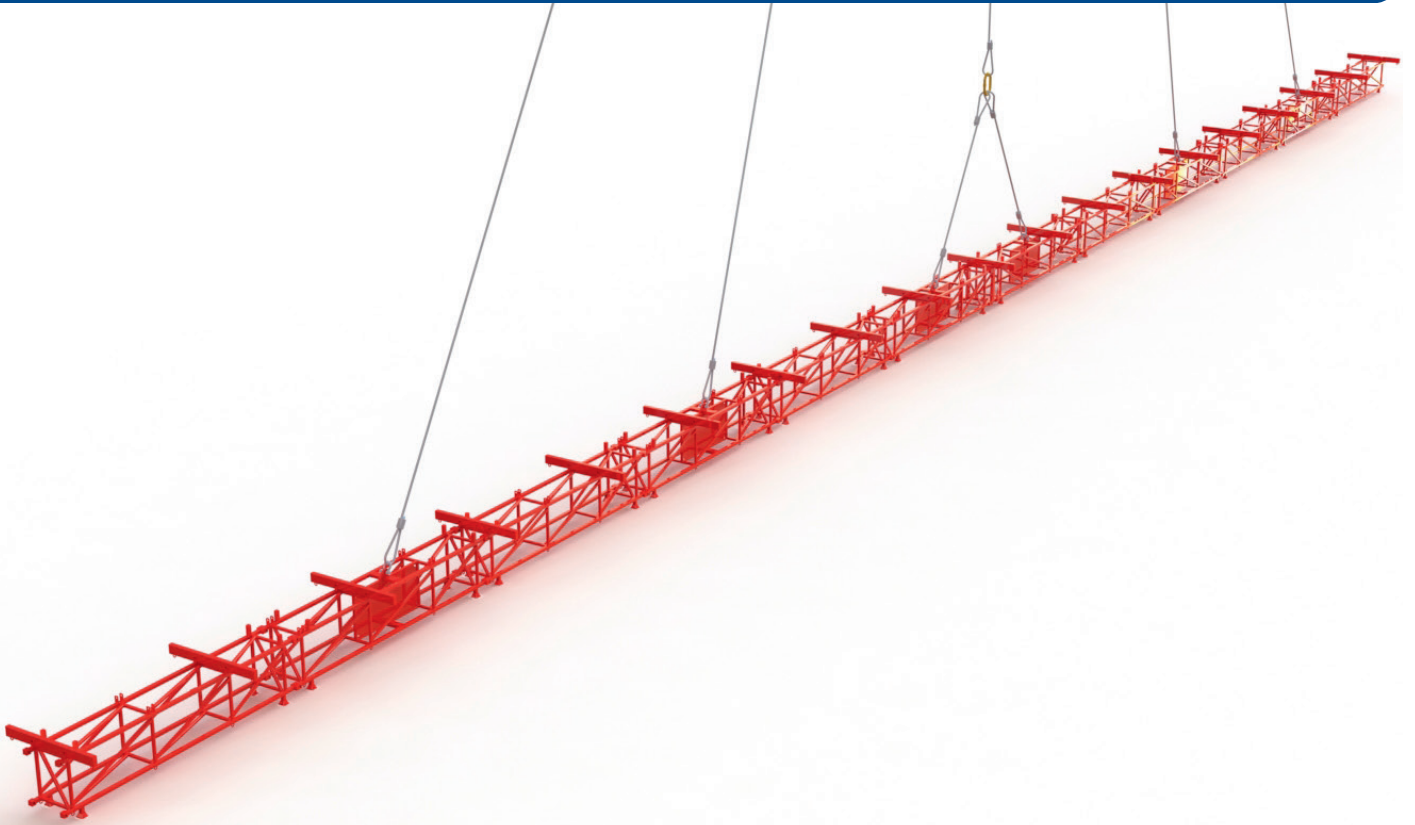

Regulations, Standards and Compliance

Each Modulift Spreader Beam Series has been proven by being Proof Load Tested in the Modulift compression test rig, and all products have been designed in accordance with the standards listed below:

UK & Europe Compliance

- BS EN 13155 Cranes – Safety – Non-fixed load lifting attachments
- DNV Standard for Certification DNVGL-ST-0378
- MOD 6 up to MOD 1100/2000 Type Approved by DNV (Spreader Beams Only)
- LOLER (Lifting Operations and Lifting Equipment Regulations)
- PUWER (Provision and Use of Work Equipment Regulations)
- EC Machinery Directive 2006/42/EC
- BS EN 1993-1: 2005: Eurocode 3

USA Compliance

- ASME B30.20: For Below-the-Hook Lifting Devices
- ASME BTH-1: Design of Below-the-Hook Lifting Devices

Australian Compliance

- AS 4991: Lifting Devices

Worldwide Compliance

- ISO 17096: Cranes, Safety, Load Lifting Attachments

DNV Standard for Certification

Modulift Spreader Beam designs conform to DNV Standard for Certification Lifting Appliances. Modulift is the first and only Spreader Beam Manufacturer in the world to have the globally recognised DNV Type Approval for all Spreader Beams up to 2000t capacity, in accordance with DNV Standard for Certification DNVGL-ST-0378, at no extra cost to the client. For those customers who require a higher level of quality standard, Modulift also provides further options for project specific 3rd party verification. When a project demands the highest level of certification Modulift are able to offer our customers varying degrees of additional DNV certification depending upon their individual QA requirements, including:

- Proof Load Test Survey Report and Record of Test
- DNV Certificate of Conformity for Manufacture & Test (CG3 in accordance with ILO convention 152)

All Modulift standard spreader beams are now **DNV Type Approved up to 2000t capacity**



Ask Modulift about the Level of Options Available to Ensure Your Safe Lift

Level 1. Standard Modulift Spreader Beams: In accordance with BS EN 13155. Available CE Marked and supplied with a Certificate of Conformity and DNV Type Approval, up to 400t available off-the-shelf.

Level 2. Individual Proof Load Testing of Modulift Spreader Beams: Modulift offer an individual Proof Load Test service with or without 3rd party verification to those requiring a higher level of certification. Please ask for further information.

Level 3. Modulift Spreader Beams with project specific DNV Certification: Although our range of Spreader Beams are now DNV Type Approved, we can also offer project specific DNV certification of individual Spreader Beams. It is the ultimate in certification and quality control for the most demanding project specification; a Modulift Spreader Beam individually certified by DNV in terms of design, manufacturing and Proof Load testing. Supplied with a design review report and Certificate of Conformity for Manufacture and Test, issued by DNV.

Engineered Products Custom Design

We can design and manufacture a Custom Lifting Solution, providing expert engineering, manufacturing excellence and quality assurance.

Because not every load fits into a standard mould, our engineering team are lifting industry experts who will work with you and your team, to custom design and build the ideal solution for your lifting requirements. With innovative thinking, we can develop the right equipment to meet your needs whether they be height, environment, weight, flexibility of use, speed of assembly, or transportation requirements to name but a few – we can design a custom solution for you.



Modulift have been building and supplying lifting equipment with high level QA requirements across the Oil & Gas, Renewable Energy, Offshore, Maritime, OEM, Aerospace and Heavy Haulage industries worldwide. We have extensive experience in delivering equipment for these critical projects successfully, on time, and to meet the project's individual requirements -we can design and manufacture a Custom Lifting Solution within 4–6 weeks!

Our sample Case Studies describe Custom Projects where we have either designed and manufactured an entirely 'Custom' lifting solution; Or we have adapted our standard designs/products -tailoring and manufacturing them to meet the highest level of QA standards.



Modulift offer a complete Design & Manufacturing service that incorporates key deliverables such as:

- ITP / Quality Plan
- Full material traceability – 3.1 or 3.2
- Weld Book: WPQR, WPS, WQTC & Weld Mapping
- Procedures & Reports: NDT, Proof Load Testing, and painting

Our team of welder/fabricators are qualified to BS EN 287-1, with specification & qualification of weld procedures to BS EN ISO 15614-1. Welding can also be carried out in compliance with other international standards.

International Standards

In addition there are several International Standards that Modulift's Spreader Beams can be designed to comply with, particularly in reference to offshore applications:

- DNV-ST-N001 – Marine Operations and Marine Warranty
- Lloyds Register: Code for Lifting Appliances in a Marine Environment
- API RP 2A-WSD
- OSHA CR 29 1926.251

Engineered Products Custom Design (continued)

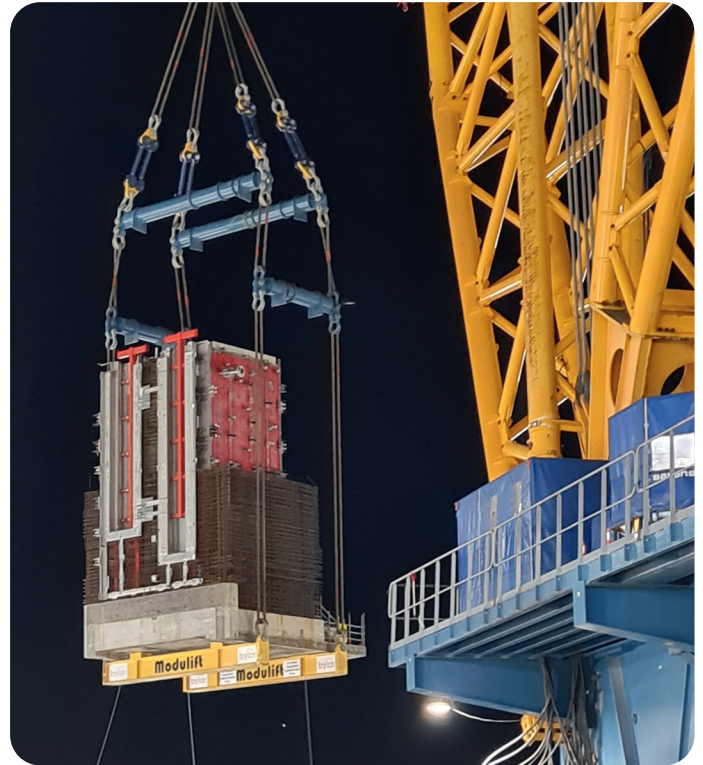

Case Studies



Construction

Modulift Spreader Beams Lift 17 90,000-lb. Buildings

Client: Bryson Crane

Bryson Crane employed two spreader beams, manufactured by Modulift, below-the-hook of a Terex all-terrain crane to lift 17 90,000-lb. prefabricated buildings into position at a communications tower in Edgewater, Florida



Breakbulk and Ports

Modulift Spreader Beam supports Iceland's oldest company

Client: Heimir og Larus

A Modulift MOD 50 spreader beam with its maximum span of 13 metres, was the perfect partner for lifting four storage tanks, each at a height of 17 metres and weighing 25t for fishing and processing company, Ísfélag Vestmannaeyja hf

Shipping and Maritime

Modulift Beams Lift and Travel With Mooring Lines

Client: Bridon

Bridon-bekaert Ropes Group supplied a pair of Modulift spreader beams with a series of sheathed spiral strand mooring lines manufactured at the former's Neptune Quay facility in Newcastle, UK for Bluewater Energy Services



Cargo, Transport and Logistics

Modulift Spreader Frame Lifts Vehicle for Filming

Client: Pinewood Studios

A CMOD spreader frame was used beneath the hook of a mobile crane, lifting a 2000kg vehicle on two occasions during the one-day shoot. The frame combined with chain slings and clamps that attached the rig to the tyres



Oil, Gas and Wind

Modulift Lifts the Worlds Largest Gas Turbine!

Client: Rolls Royce

Modulift designed and built spreaders to lift the world's most powerful gas turbine, the Rolls-Royce MT30, into the Royal Navy's new aircraft carrier HMS Queen Elizabeth. Rolls Royce viewed the lifting of the gas turbine as a "significant milestone" in the Queen Elizabeth ship building programme

Lifting Gear

Modulift and Siemens Design Rig for Dockside Lifts

Client: Siemens

Two vertical Benson-type Heat Recovery Steam Generators, the largest HRSGs Siemens have ever constructed, were lifted with a rig utilising a total of 16 34t capacity MOD 34 beams in addition to slings, shackles, tie-plates, and other rigging gear



Engineered Lifting Products High QA

ST3 Lifts Jacket Foundations for Wind Farm with Modulift Beams



Modulift has supplied two large spreader beams to complete a rig that will lift 20 wind farm jacket foundations onto vessels at ST3 Offshore's dockside location in Szczecin, Poland, close to the country's northwestern border with Germany. The jackets are bound for Cuxhaven and will eventually be installed at the Borkum Riffgrund 2 offshore wind farm.

The two beams, MOD 400/600s, both 8m-long, were used in an inverted configuration above another Modulift beam, an 800/1000, which was hired in from Schmidbauer GmbH & Co. KG. The beams combined with shackles and other rigging gear, including delta plates, to form the rig beneath the hooks of a rail-mounted, 117m-high, 1,400t capacity gantry crane.

The 400/600s offer up to 600t at 14m or 44 ft. and up to 24m or 78 ft. at a lower capacity, while the 800/1000 can lift up to 1,000t at 15m or 51 ft. and up to 26m or 85 ft. at a lower capacity. The foundation jackets weigh 700t apiece and stand 52m high. They are lifted in their entirety onto a barge that can transport three at a time.

John Baker, sales and marketing director at Modulift, explained that the top two 400/600 beams were used in an inverted (upside down) configuration to utilise the four hoist hooks on the crane, and allow the lower slings to come down to a single point on top of the lower 1,000t beam; below that again, two delta plates and a horizontal sling created the vertical angle for the bottom slings that attached the rig to the top of each jacket.

Baker added: "Modulift spreader beams are put into compression when loaded so another beam wouldn't have been suitable at the bottom of the rig between the delta plates because the forces



“We are continuing to welcome greater demand from the wind energy sector and look forward to meeting many more challenges in the future.”

applied are tensile rather than compressive. A wire rope grommet acted as a tie sling between the delta plates and created the vertical sling angle for the bottommost slings in the rig.” ST3’s facility is specifically designed for the production of transition pieces, jacket foundations and offshore wind foundation components and other large fabricated structures. In this case, the jacket foundations will be assembled at their destination with 10m-high suction buckets, used to anchor the structures. Water will be pumped out of the buckets to lower pressure and, combined with the weight of the foundation, the structures will sink to the sea floor.

At the time of writing, the first phase of loadout remains ongoing. The rig will stay in Szczecin for the duration of the project. A different lifting and rigging solution will take the weight of offload and installation at Borkum, which is one of the largest offshore power plants in Germany, with a capacity of 450MW, expected to supply electricity to nearly 500,000 households per year. Baker concluded: “It has been fascinating to spend time at the Szczecin site and work with the great team there to consult on this below-the-hook application. The inverted solution was an effective way to utilise the four hoists on the crane and further innovation was demonstrated by the delta plates further down the rig.”





Modulift UK Ltd
4 Holton Point, Holton Road
Holton Heath Trading Park, Poole
BH16 6FL, United Kingdom
www.modulift.com

GE-UK
© Copyright Modulift. All rights reserved.